

## INSTALLATION INSTRUCTIONS FOR:

C5SZ-13A366-AS Sequential system kit for 1965 - 1966 Thunderbirds built before 11/17/65

C6SZ-13A366-AS Sequential system kit for 1966 Thunderbirds built from 11/17/65

### INTRODUCTION:

This sequential system kit eliminates the mechanical motor-driven sequencers and relays used on the rubber pad in trunks of the 1965-1966 Thunderbirds. *One* system module replaces all these parts found in the Thunderbird trunk: Sequential flasher and motor (the noisy one), directional relay (the big one), and the stop lamp relay. It plugs into the original wiring harness and mounts in the original location without any modifications. Parts included in this kit are: System control unit with wiring and a troubleshooting guide.

### INSTALLATION:

1. Locate the factory sequential system mounted on the rubber pad behind the back seat on the passenger side (Figures 1 and 2). Remove the spare tire for access.
2. After removing the fiberglass insulation wrap taped around the original system, disconnect all connectors from the sequencer motor, directional relay, and stop lamp relay. Remove the rubber pad from the car. Remove the attaching nuts, bolts, and the old relays. The insulation and old relays will not be reused.
3. Mount the unit to the rubber pad using the original hardware as shown in Figure 3. Plug in the sequential system connectors into the wiring harness. Plug in the 2-pin brown jumper wire into its matching connector on the car wiring harness. On the 1965 and early 1966 cars, plug in the stop lamp wires as shown in Figure 4. Also bolt the black lug to ground. Remount the rubber pad on the car.
4. Make sure that the vehicle battery is fully charged and that the vehicle is running before testing. A low battery may cause the indicator lights (on the fender) to not flash, but the front and rear turn signal lights will still function properly. This is normally due to heavy loads (AC, headlights on, brake lights on, etc.) and will happen with the factory system. If this occurs, check all bulbs, sockets, and connectors in the system. For more troubleshooting information, consult the trouble-shooting section of these instructions.

### WARRANTY:

The sequential system kits are covered by a limited warranty for two years after purchase. Should the unit fail during this warranty period, it will be repaired or replaced upon prepaid return to your dealer. This limited warranty does not include repair of damage to the unit resulting from accident, disaster, misuse, abuse, unauthorized modifications or any use beyond normal operating conditions. This warranty excludes any coverage for incidental or consequential damages.

CE2TINS 6/95 C.U.

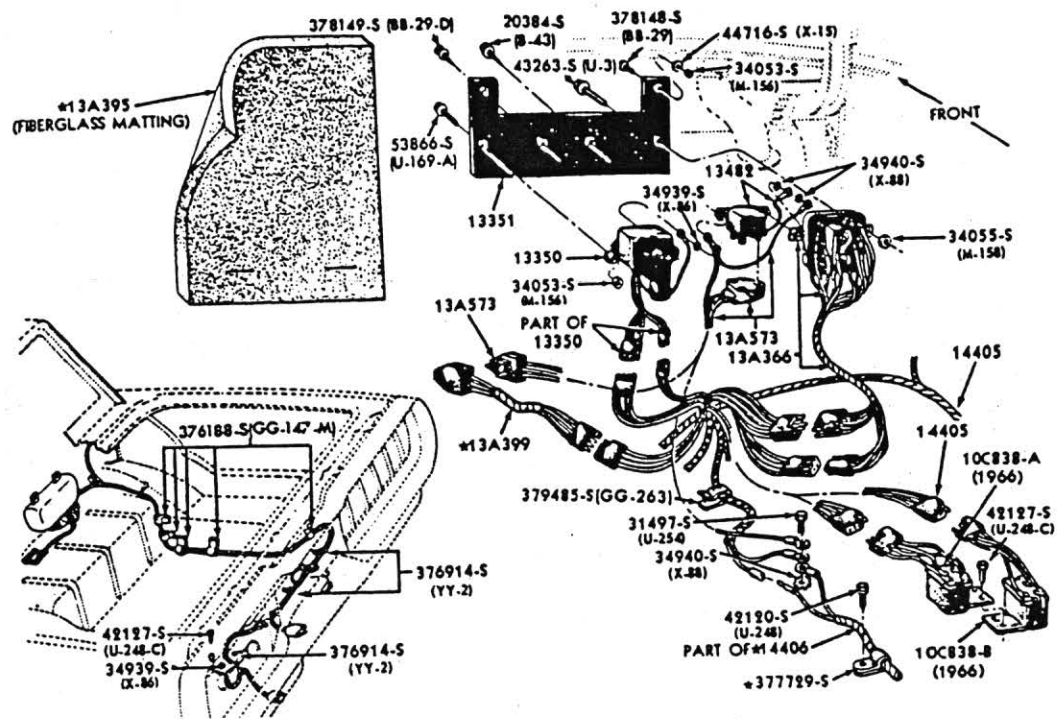

Figure 1. Turn Signal Sequencer Location - 1965 -1966 Thunderbirds built before 11/17/65

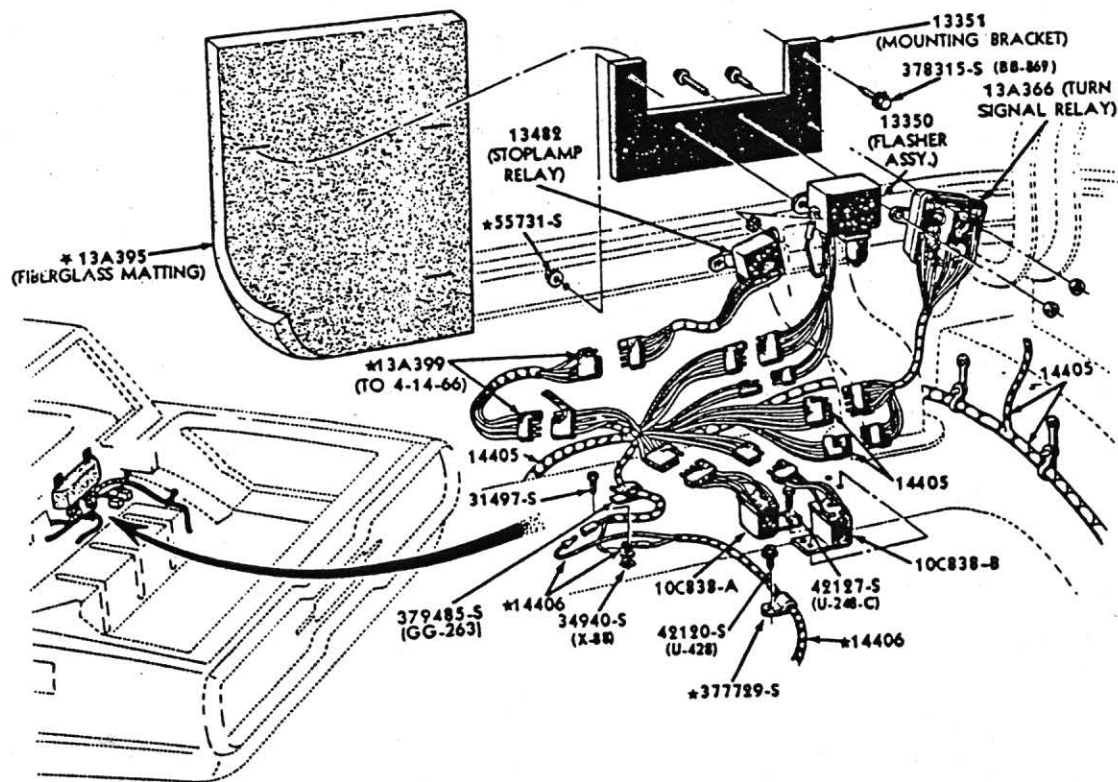

Figure 2. Turn Signal Sequencer Location - 1966 Thunderbirds built from 11/17/65

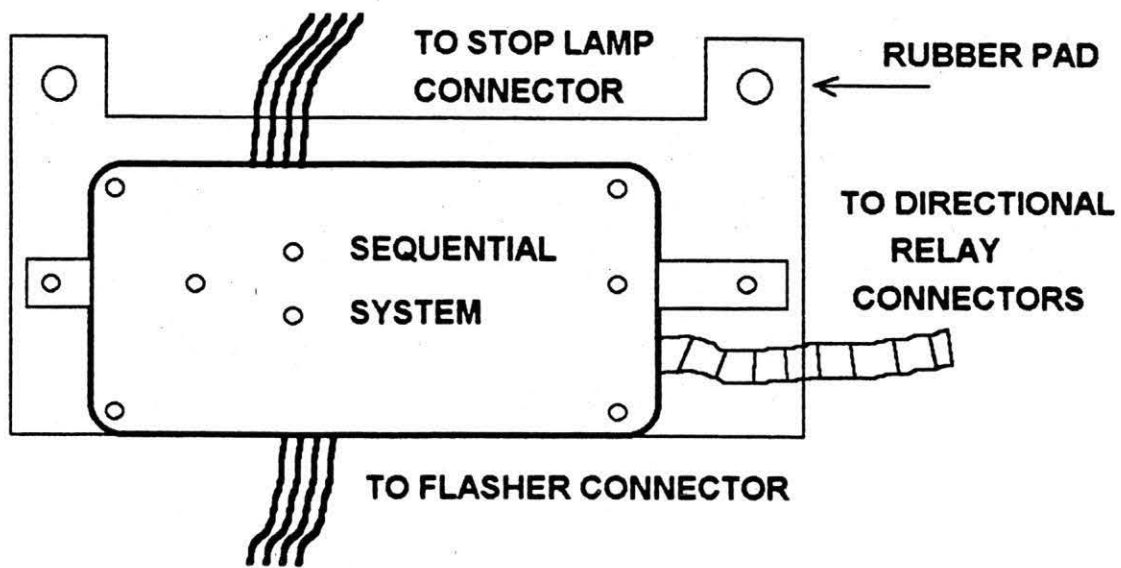
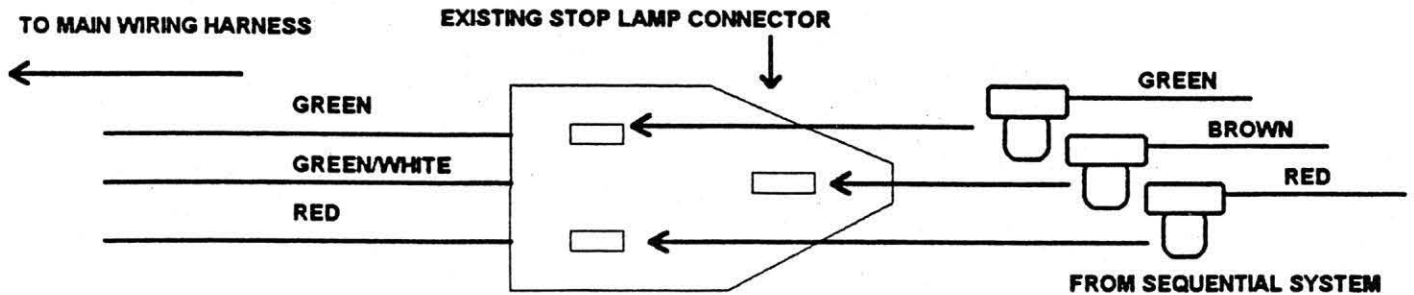

Figure 3. Electronic Sequencer Mounting



PLUG IN 3 RIGHT ANGLE TERMINALS INTO THE PIN SOCKETS AS SHOWN.

Figure 4. Stop lamp wire connections - 1965 and early 1966

## Troubleshooting Ford Thunderbird Sequential Turn Signals

This article covers troubleshooting 1965-1966 Ford Thunderbird sequential turn signals. The turn signal system has five electro-mechanical parts: the turn signal switch, (located in the steering column), a turn signal relay (located under the dash on the pedal support), a directional relay, and a motor-driven sequential flasher located in the trunk behind the backseat . The 1966 Town series also has a pair of emergency flasher relays bolted to the upper trunk level floor just to the right of the spare tire. The most failure prone parts are the mechanical sequential flasher, the turn signal switch, and the stop lamp relay. Circuit diagrams may be found in the appropriate year factory shop manual.

Basically, the system works as follows: when the directional lever on the turn signal switch is moved, it completes circuits that select and feed power to the corresponding bank of lights. Power for the lights is fed through the turn signal relay to the sequencer. The sequencer has three cams that, when rotated, depress switches corresponding to the inboard, center, and outboard tail lights. The power is then routed to the directional relay. This two-sectioned (right and left) relay routes power through to the selected bank of lights. Since brake lights are not sequenced, the directional relay allows all lights to turn on simultaneously when the brake light power feed is energized. But when the turn signal switch is actuated, the brake light power feed is disconnected and the turn signal feed is activated to allow the directional signal to override the brake lights.

Now that you understand a little about how your turn signal system works, you can start troubleshooting. You will need a VOM (Volt-Ohm-Meter) and the circuit diagram for your year car. The most common complaints are: no turn signals, one or more lights on but not flashing, and one or more lights flashing. Obviously, the first place to check is the fuse in the fuse box. The next item is to check all bulbs and their sockets. If these are all good, then now the real sleuthing must begin!

### No turn signals:

When the turn signal lever is depressed, no lights come on anywhere. Listen to the directional relay for a click while moving the turn signal lever. If there is no sound, disconnect the turn signal switch from the harness and check it according to Table 1. The table shows wire pairs that should be shorted together when the switch is in the position indicated. If any of the connections are open, replace the switch. Usually the switch has failed when the plastic around the riveted contacts appears to be burnt or melted. This can only be seen with the steering wheel removed.

#### LEFT-TURN

Brown, Yellow  
White, Orange-Yellow, Orange-Black

#### RIGHT-TURN

Brown, Red  
Violet, Orange-Yellow, Orange-Black

Table 1. 1965 or 1966 Turn signal switch connections

### Some or all lights on but not flashing:

This usually means that the motor in the sequential flasher has quit. Remove the white cover from the sequencer and see if the motor is turning the cam. FORD has discontinued the unit but an electronic replacement is available from your parts dealer.

**Indicator lights on fender not flashing:**

The directional indicator relay (under the dash) is calibrated to flash the indicator lights only when all four lights (3 in rear, 1 in front) are on. A burned out bulb can cause the indicator lights to stop flashing. Heavy loads on the system (AC, headlights on, brake lights on) can also cause this problem. The directional indicator relay can weaken with age and cause these symptoms.

**One or more lights flashing:**

If all bulbs are OK, the trouble is most likely in the sequential flasher or the directional relay. The switch contacts erode away with age. sometimes they can be cleaned up with an ignition points file, but this is just a temporary fix. The best solution is to replace the sequential flasher with an electronic unit. If the directional relay is bad, a replacement is available.

**Brake lights on all the time:**

First, check the brake light switch under the dash. If the switch is not stuck on, then the stop lamp relay in the trunk is bad.

**Emergency flashers not working:**

First, check the flasher can under the dash. On the 1966 Town series cars, one of the emergency flasher relays located on the upper trunk shelf next to the spare tire may be bad. Check for a clicking noise from these relays when the emergency flasher button is pressed. Check for power through these relays.

Part Description	1965 & 1966 T-Bird (before 11/17/65)	1966 T-Bird (from 11/17/65)
<b>OEM FORD</b>		
Turn indicator relay (under dash)	C5SZ-13A366-C	C5SZ-13A366-C
Directional relay (in trunk)	C7WY-13A366-A	C7WY-13A366-A
Sequential flasher	C5SZ-13350-A	C5SZ-13350-A
Turn signal switch (w/o cruise)	C5SZ-13341-B	C5SZ-13341-B
Stop light relay	C5SZ-13482-A	C7SZ-13482-B
<b>REPLACEMENT PARTS</b>		
Electronic sequential flasher	TE-1	TE-1
Directional relay (replacement)	C7WY-13A366-AR	C7WY-13A366-AR
Stop light relay		C7SZ-13482-BR
Electronic system (replaces sequential flasher, directional relay and stop lamp relay)	C5SZ-13A366-AS	C6SZ-13A366-AS

Table 2. Turn Signal Parts list

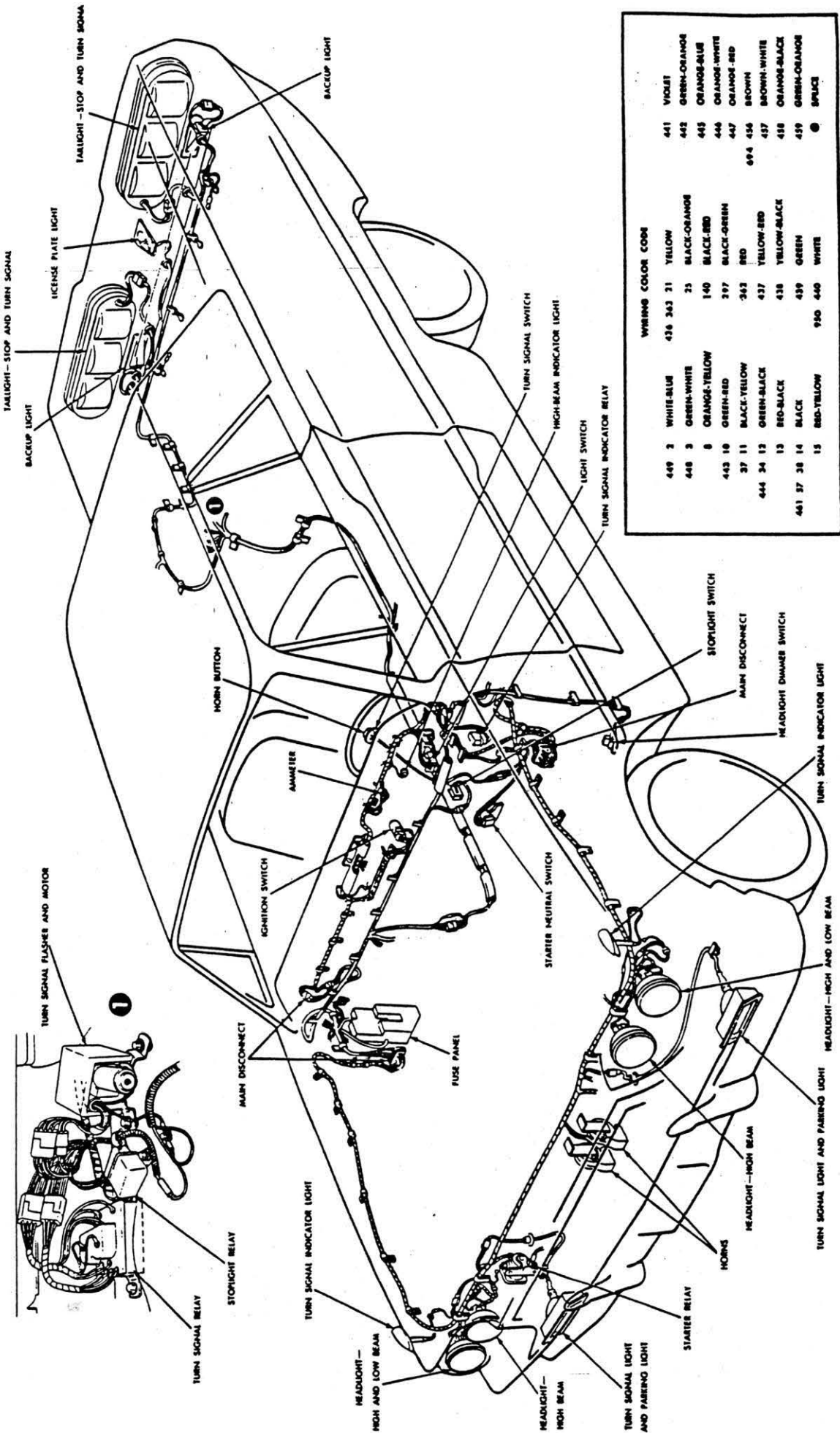

# 1965 THUNDERBIRD EXTERIOR LIGHTING, TURN SIGNALS AND HORNS

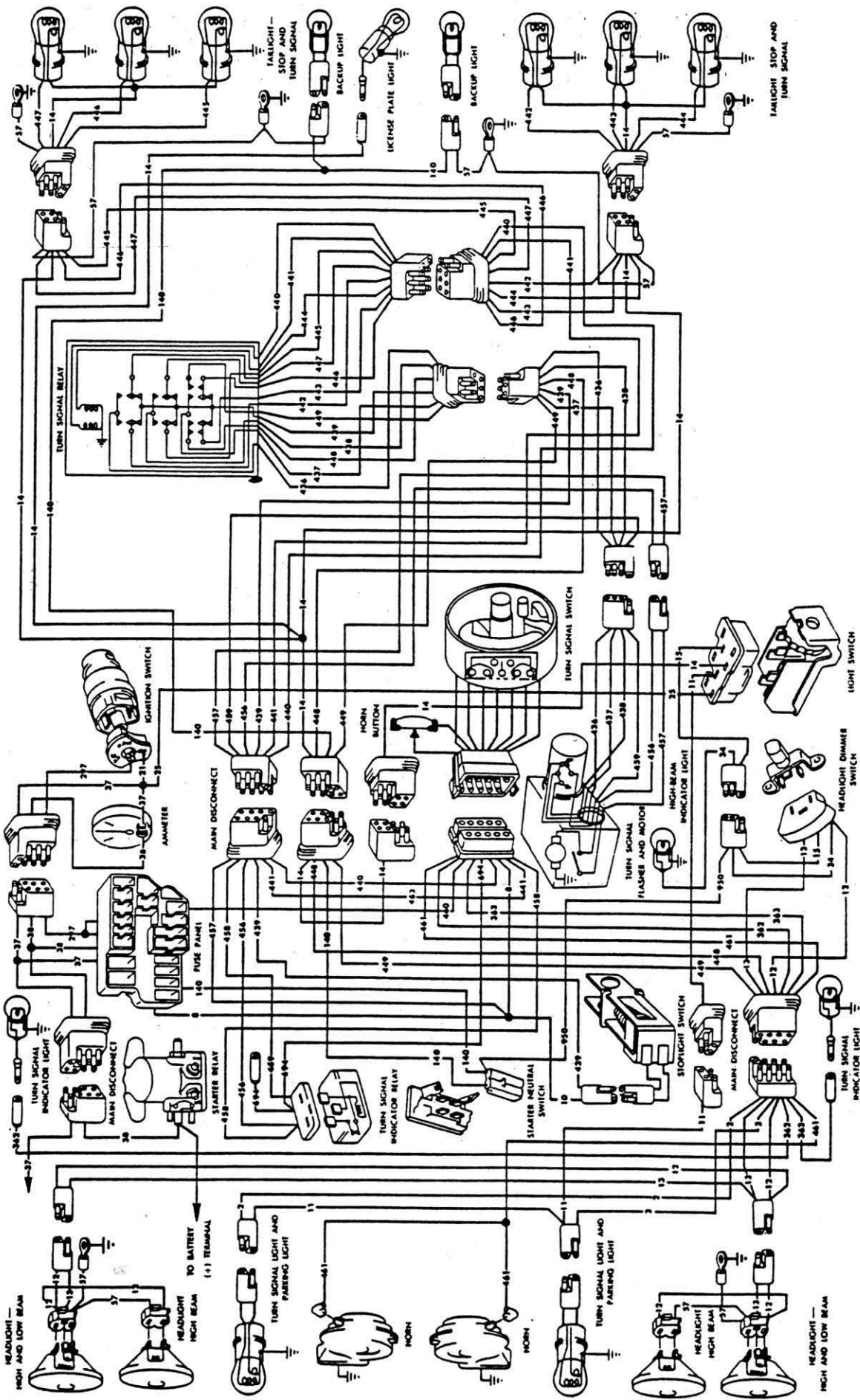

**1965 THUNDERBIRD EXTERIOR LIGHTING, TURN SIGNALS AND HORNS**

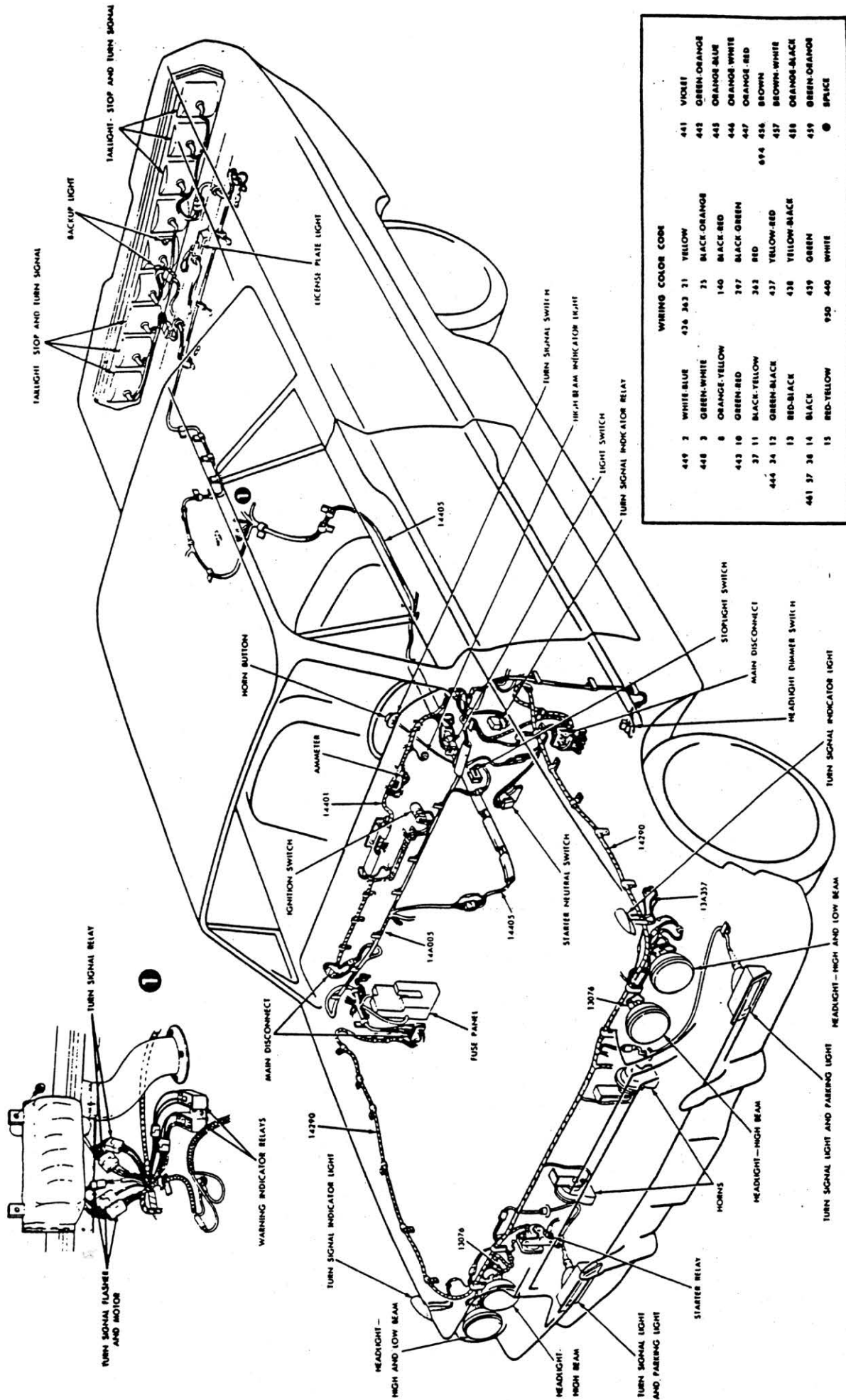

WIRING COLOR CODE			
449 7	WHITE-BLUE	436 263 21	YELLOW
448 3	GREEN-WHITE	75	BLACK-ORANGE
445 8	ORANGE-YELLOW	140	BLACK-RED
443 10	GREEN-RED	287	BLACK-GREEN
37 11	BLACK-YELLOW	262	RED
444 34 12	GREEN-BLACK	437	YELLOW-RED
13	RED-BLACK	438	YELLOW-BLACK
461 37 36 14	BLACK	439	GREEN
15	RED-YELLOW	930 440	WHITE

# 1966 THUNDERBIRD EXTERIOR LIGHTING